

This Page Is Inserted by IFW Operations
and is not a part of the Official Record

BEST AVAILABLE IMAGES

Defective images within this document are accurate representations of the original documents submitted by the applicant.

Defects in the images may include (but are not limited to):

- BLACK BORDERS
- TEXT CUT OFF AT TOP, BOTTOM OR SIDES
- FADED TEXT
- ILLEGIBLE TEXT
- SKEWED/SLANTED IMAGES
- COLORED PHOTOS
- BLACK OR VERY BLACK AND WHITE DARK PHOTOS
- GRAY SCALE DOCUMENTS

IMAGES ARE BEST AVAILABLE COPY.

As rescanning documents *will not* correct images,
Please do not report the images to the
Image Problem Mailbox.

(12) INTERNATIONAL APPLICATION PUBLISHED UNDER THE PATENT COOPERATION TREATY (PCT)

(19) World Intellectual Property Organization
International Bureau



INTERNATIONAL BUREAU OF PATENT COOPERATION
3, rue de Woodville
CHAMBERLIN (FRANCE)

(43) International Publication Date
17 July 2003 (17.07.2003)

PCT

(10) International Publication Number
WO 03/058022 A2

- (51) International Patent Classification⁷: **E21B**
- (21) International Application Number: PCT/US02/39425
- (22) International Filing Date:
10 December 2002 (10.12.2002)
- (25) Filing Language: English
- (26) Publication Language: English
- (30) Priority Data:
60/343,674 27 December 2001 (27.12.2001) US
- (71) Applicant (for all designated States except US): **ENVEN-
TURE GLOBAL TECHNOLOGY** [US/US]; 16200 A.
Park Row, Houston, TX 77084 (US).

- Land, Tomball, TX 77375 (US). **JACKSON, Tance, Alan** [US/US]; 7209 Ridgemoor Lane, Plano, TX 75025 (US).
- (74) Agents: **MATTINGLY, Todd** et al.; Haynes and Boone, LLP, Suite 4300, 1000 Louisiana Street, Houston, TX 77002-5012 (US).
- (81) Designated States (national): AE, AG, AI, AM, AT, AU, AZ, BA, BB, BG, BR, BY, BZ, CA, CH, CN, CO, CR, CU, CZ, DE, DK, DM, DZ, EC, EE, ES, FI, GB, GD, GE, GH, GM, HR, HU, ID, IL, IN, IS, JP, KE, KG, KP, KR, KZ, LC, LK, LR, LS, LT, LU, LV, MA, MD, MG, MK, MN, MW, MX, MZ, NO, NZ, PL, PT, RO, RU, SD, SE, SG, SK, SL, TJ, TM, TR, TT, TZ, UA, UG, US, UZ, VN, YU, ZA, ZW.
- (84) Designated States (regional): ARIPO patent (GH, GM, KE, LS, MW, MZ, SD, SI, SZ, TZ, UG, ZM, ZW), Eurasian patent (AM, AZ, BY, KG, KZ, MD, RU, TJ, TM), European patent (AT, BE, BG, CH, CY, CZ, DE, DK, EE, ES, FI, FR, GB, GR, IE, IT, LU, MC, NL, PT, SE, SI, SK, TR), OAPI patent (BF, BJ, CF, CG, CI, CM, GA, GN, GQ, GW, ML, MR, NE, SN, TD, TG).

- (72) Inventors: and
- (75) Inventors/Applicants (for US only): **WADDELL, Kevin, Karl** [US/US]; 11007 Sprucedale Court, Houston, TX 77077 (US). **BULLOCK, Michael, Dennis** [US/GB]; The Beeches, 25 Hillhead Road, Aberdeen, AB15 9EJ (GB). **HOCKADAY, Joel, Gray** [US/US]; 17318 Ginger Fields

Published:
— without international search report and to be republished upon receipt of that report

[Continued on next page]

(54) Title: SEAL RECEPTACLE USING EXPANDABLE LINER HANGER

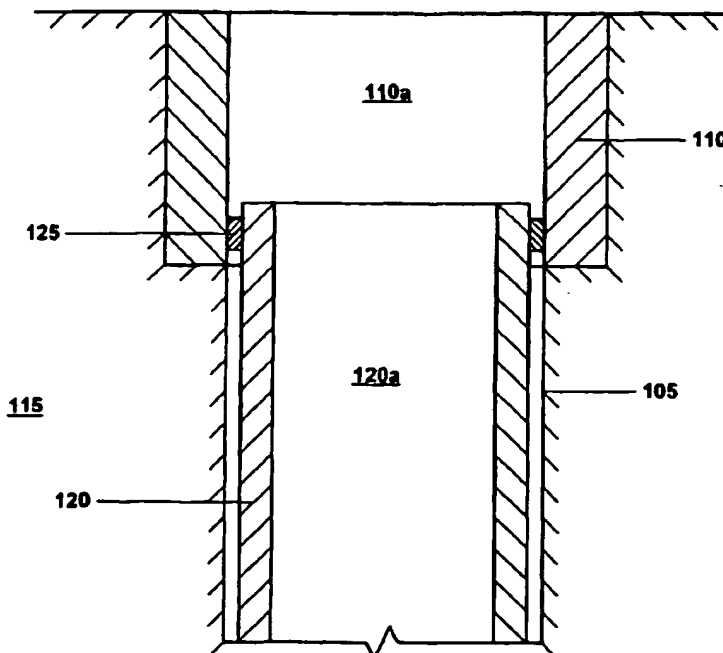

(57) Abstract: The end of an expandable liner hanger provides a receptacle for another tubular liner.



WO 03/058022 A2

For two-letter codes and other abbreviations, refer to the "Guidance Notes on Codes and Abbreviations" appearing at the beginning of each regular issue of the PCT Gazette.

SEAL RECEPTACLE USING EXPANDABLE LINER HANGER**Cross Reference To Related Applications**

[0001] The present application claims the benefit of the filing dates of: (1) U.S. provisional patent application serial no. 60/343,674, attorney docket no. 25791.68, filed on 12/27/2001, the disclosure of which is incorporated herein by reference.

[0002] The present application is related to the following: (1) U.S. patent application serial no. 09/454,139, attorney docket no. 25791.03.02, filed on 12/3/1999, (2) U.S. patent application serial no. 09/510,913, attorney docket no. 25791.7.02, filed on 2/23/2000, (3) U.S. patent application serial no. 09/502,350, attorney docket no. 25791.8.02, filed on 2/10/2000, (4) U.S. patent application serial no. 09/440,338, attorney docket no. 25791.9.02, filed on 11/15/1999, (5) U.S. patent application serial no. 09/523,460, attorney docket no. 25791.11.02, filed on 3/10/2000, (6) U.S. patent application serial no. 09/512,895, attorney docket no. 25791.12.02, filed on 2/24/2000, (7) U.S. patent application serial no. 09/511,941, attorney docket no. 25791.16.02, filed on 2/24/2000, (8) U.S. patent application serial no. 09/588,946, attorney docket no. 25791.17.02, filed on 6/7/2000, (9) U.S. patent application serial no. 09/559,122, attorney docket no. 25791.23.02, filed on 4/26/2000, (10) PCT patent application serial no. PCT/US00/18635, attorney docket no. 25791.25.02, filed on 7/9/2000, (11) U.S. provisional patent application serial no. 60/162,671, attorney docket no. 25791.27, filed on 11/1/1999, (12) U.S. provisional patent application serial no. 60/154,047, attorney docket no. 25791.29, filed on 9/16/1999, (13) U.S. provisional patent application serial no. 60/159,082, attorney docket no. 25791.34, filed on 10/12/1999, (14) U.S. provisional patent application serial no. 60/159,039, attorney docket no. 25791.36, filed on 10/12/1999, (15) U.S. provisional patent application serial no. 60/159,033, attorney docket no. 25791.37, filed on 10/12/1999, (16) U.S. provisional patent application serial no. 60/212,359, attorney docket no. 25791.38, filed on 6/19/2000, (17) U.S. provisional patent application serial no. 60/165,228, attorney docket no. 25791.39, filed on 11/12/1999, (18) U.S. provisional patent application serial no. 60/221,443, attorney docket no. 25791.45, filed on 7/28/2000, (19) U.S. provisional patent application serial no. 60/221,645, attorney docket no. 25791.46, filed on 7/28/2000, (20) U.S. provisional patent application serial no. 60/233,638, attorney docket no. 25791.47, filed on 9/18/2000, (21) U.S. provisional patent application serial no. 60/237,334, attorney docket no. 25791.48, filed on 10/2/2000, (22) U.S. provisional patent application serial no. 60/270,007, attorney docket no. 25791.50, filed on 2/20/2001, (23) U.S. provisional patent application serial no. 60/262,434, attorney docket no. 25791.51, filed on 1/17/2001, (24) U.S. provisional patent application serial no. 60/259,486, attorney docket no. 25791.52, filed on 1/3/2001, (25) U.S. provisional patent application serial no. 60/303,740, attorney docket no. 25791.61, filed on 7/6/2001, (26) U.S. provisional patent application serial no. 60/313,453, attorney docket no. 25791.59, filed on 8/20/2001, (27) U.S. provisional patent application serial no. 60/317,985, attorney docket no. 25791.67, filed on 9/6/2001, (28) U.S. provisional patent application serial no. 60/3318,386, attorney docket no. 25791.67.02, filed on 9/10/2001, (29) U.S. utility patent application serial no.

09/969,922, attorney docket no. 25791.69, filed on 10/3/2001, and (30) U.S. utility patent application serial no. 10/016,467, attorney docket no. 25791.70, filed on December 10, 2001, the disclosures of which are incorporated herein by reference.

Background of the Invention

[0003] This invention relates generally to oil and gas exploration, and in particular to isolating certain subterranean zones to facilitate oil and gas exploration.

[0004] During oil exploration, a wellbore typically traverses a number of zones within a subterranean formation. Some of these subterranean zones will produce oil and gas, while others will not. Further, it is often necessary to isolate subterranean zones from one another in order to facilitate the exploration for and production of oil and gas. Existing methods for isolating subterranean production zones in order to facilitate the exploration for and production of oil and gas are complex and expensive.

[0005] The present invention is directed to overcoming one or more of the limitations of the existing processes for isolating subterranean zones during oil and gas exploration.

Summary of the Invention

[0006] According to one aspect of the present invention, an apparatus is provided that includes a subterranean formation defining a wellbore, a tubular wellbore casing positioned within and coupled to the wellbore, a first tubular liner positioned within the wellbore overlapping with and coupled to the wellbore casing, a second tubular liner positioned within the wellbore and overlapping with and coupled to the first tubular liner. The second tubular liner is coupled to the first tubular liner by: machining an end of the first tubular liner, and inserting an end of the second tubular liner into the machined end of the first tubular liner.

[0006] According to another aspect of the present invention, a method for extracting fluidic materials from a subterranean formation including a wellbore that traverses the formation and a wellbore casing positioned within and coupled to the wellbore is provided that includes coupling an end of a tubular liner to an end of the wellbore casing, machining an end of the tubular liner, inserting an end of another tubular liner into the machined end of the tubular liner, and sealing the interface between the other tubular liner and the wellbore casing.

[0008] According to another aspect of the present invention, a system for extracting fluidic materials from a subterranean formation including a wellbore that traverses the formation and a wellbore casing positioned within and coupled to the wellbore is provided that includes means for coupling an end of a tubular liner to an end of the wellbore casing, means for machining an end of the tubular liner, means for inserting an end of another tubular liner into the machined end of the tubular liner, and means for sealing the interface between the other tubular liner and the wellbore casing.

[0009] According to another aspect of the present invention, in an apparatus comprising a subterranean formation defining a wellbore that includes a wellbore casing positioned within and coupled to the wellbore and a tubular liner coupled to an end of the wellbore casing, a method of conveying fluidic

materials to and from the tubular liner is provided that includes machining the end of the tubular liner, inserting and supporting an end of another tubular liner in the machined end of the tubular liner, and conveying fluidic materials to and from the tubular liner using the other tubular liner.

Brief Description of the Drawings

[0010] FIG. 1 is a fragmentary cross-sectional view illustrating a liner coupled to a preexisting wellbore casing.

[0011] Fig. 2 is a fragmentary cross sectional illustration of the liner of Fig. 1 after machining the end of the liner.

[0012] Fig. 2a is a fragmentary cross sectional illustration of the machined end of the liner of Fig. 2.

[0013] Fig. 3 is a fragmentary cross sectional illustration of the insertion of a seal assembly into the machined end of the liner of Fig. 2.

[0014] Fig. 4 is a fragmentary cross sectional of the seal assembly of Fig. 3.

[0015] Fig. 4a is a fragmentary cross sectional illustration of one of the seals of the seal assembly of Fig. 4.

[0016] Fig. 4b is a fragmentary cross sectional illustration of another one of the seals of the seal assembly of Fig. 4.

[0017] Fig. 4c is a fragmentary cross sectional illustration of another one of the seals of the seal assembly of Fig. 4.

Detailed Description of the Illustrative Embodiments

[0018] Referring to Fig. 1, a wellbore 105 including a casing 110 that defines a passage 110a is positioned in a subterranean formation 115. During exploration of the subterranean formation 115, the wellbore 105 may be extended in a well known manner. A tubular liner 120 that defines a passage 120a including an elastomeric seal 125 may then be positioned in the extended portion of the wellbore 105 and coupled to the end of the casing 110 by radially expanding and plastically deforming the upper end of the tubular liner 120 into engagement with the lower end of the casing. In this manner, the elastomeric seal 125 is compressed into engagement with the casing 110 thereby creating sufficient frictional force to seal the interface between the liner 120 and the casing and support the weight of the liner using the casing.

[0019] In several exemplary embodiments, the liner 120 is radially expanded and plastically deformed into engagement with the casing 110 in a conventional manner and/or using one or more of the methods and apparatus disclosed in one or more of the following: (1) U.S. patent application serial no. 09/454,139, attorney docket no. 25791.03.02, filed on 12/3/1999, (2) U.S. patent application serial no. 09/510,913, attorney docket no. 25791.7.02, filed on 2/23/2000, (3) U.S. patent application serial no. 09/502,350, attorney docket no. 25791.8.02, filed on 2/10/2000, (4) U.S. patent application serial no. 09/440,338, attorney docket no. 25791.9.02, filed on 11/15/1999, (5) U.S. patent application serial no. 09/523,460, attorney docket no. 25791.11.02, filed on 3/10/2000, (6) U.S. patent application serial no.

09/512,895, attorney docket no. 25791.12.02, filed on 2/24/2000, (7) U.S. patent application serial no. 09/511,941, attorney docket no. 25791.16.02, filed on 2/24/2000, (8) U.S. patent application serial no. 09/588,946, attorney docket no. 25791.17.02, filed on 6/7/2000, (9) U.S. patent application serial no. 09/559,122, attorney docket no. 25791.23.02, filed on 4/26/2000, (10) PCT patent application serial no. PCT/US00/18635, attorney docket no. 25791.25.02, filed on 7/9/2000, (11) U.S. provisional patent application serial no. 60/162,671, attorney docket no. 25791.27, filed on 11/1/1999, (12) U.S. provisional patent application serial no. 60/154,047, attorney docket no. 25791.29, filed on 9/16/1999, (13) U.S. provisional patent application serial no. 60/159,082, attorney docket no. 25791.34, filed on 10/12/1999, (14) U.S. provisional patent application serial no. 60/159,039, attorney docket no. 25791.36, filed on 10/12/1999, (15) U.S. provisional patent application serial no. 60/159,033, attorney docket no. 25791.37, filed on 10/12/1999, (16) U.S. provisional patent application serial no. 60/212,359, attorney docket no. 25791.38, filed on 6/19/2000, (17) U.S. provisional patent application serial no. 60/165,228, attorney docket no. 25791.39, filed on 11/12/1999, (18) U.S. provisional patent application serial no. 60/221,443, attorney docket no. 25791.45, filed on 7/28/2000, (19) U.S. provisional patent application serial no. 60/221,645, attorney docket no. 25791.46, filed on 7/28/2000, (20) U.S. provisional patent application serial no. 60/233,638, attorney docket no. 25791.47, filed on 9/18/2000, (21) U.S. provisional patent application serial no. 60/237,334, attorney docket no. 25791.48, filed on 10/2/2000, (22) U.S. provisional patent application serial no. 60/270,007, attorney docket no. 25791.50, filed on 2/20/2001; (23) U.S. provisional patent application serial no. 60/262,434, attorney docket no. 25791.51, filed on 1/17/2001; (24) U.S. provisional patent application serial no. 60/259,486, attorney docket no. 25791.52, filed on 1/3/2001; (25) U.S. provisional patent application serial no. 60/303,740, attorney docket no. 25791.61, filed on 7/6/2001; (26) U.S. provisional patent application serial no. 60/313,453, attorney docket no. 25791.59, filed on 8/20/2001; (27) U.S. provisional patent application serial no. 60/317,985, attorney docket no. 25791.67, filed on 9/6/2001; (28) U.S. provisional patent application serial no. 60/3318,386, attorney docket no. 25791.67.02, filed on 9/10/2001; (29) U.S. utility patent application serial no. 09/969,922, attorney docket no. 25791.69, filed on 10/3/2001; and (30) U.S. utility patent application serial no. 10/016,467, attorney docket no. 25791.70, filed on December 10, 2001, the disclosures of which are incorporated herein by reference.

[0020] In an exemplary embodiment, as illustrated in Figs. 2 and 2a, the upper end 120a of the liner 120 is then machined to provide a first beveled portion 120aa and a second beveled portion 120ab. In an exemplary embodiment, the angle of attack of the first beveled portion 120aa is about 45° and the angle of attack of the second beveled portion 120ab is about 15°.

[0021] As illustrated in Figs. 3 and 4, an end 135a of a tubular locator 135 that defines a passage 135b and includes a flange 135c and an external threaded connection 135d at another end 135e is then inserted into the upper end 120a of the liner 120. The flange 135c further includes a tapered end face 135ca that mates with the first portion 120aa of the machined upper end 120a of the liner 120. In this manner, the

tubular locator 135 mates with and is supported by the upper end 120a of the liner 120. Furthermore, the compound angular profile of the combination of the first and second portions, 120aa and 120ab, of the machined upper end 120a of the liner 120 facilitates the insertion of the end 135a of the tubular locator 135 within the upper end of the liner.

[0022] An end 140a of a tubular seal assembly 140 that defines a passage 140b and includes external seals 140c, 140d, and 140e, is removably coupled to the external threaded connection 135d of the end 135e of the tubular locator 135 by an internal threaded connection 140f. A portion of the other end 140g of the tubular seal assembly 140 is tapered at approximately an angle of about 45 degrees in order to facilitate the insertion and removal of equipment.

[0023] As illustrated in Fig. 4a, in an exemplary embodiment, the external seal 140c includes an elastomeric seal 140ca that is retained within an external groove 140cb by a retaining element 140cc. In an exemplary embodiment, the external seals 140c fluidically seal the interface between the tubular seal assembly 140 and the wellbore casing 110.

[0024] As illustrated in Fig. 4b, in an exemplary embodiment, the external seal 140d includes an elastomeric seal 140da that is retained within an external groove 140db by a retaining element 140dc. In an exemplary embodiment, the external seals 140d fluidically seal the interface between the tubular seal assembly 140 and the wellbore casing 110.

[0025] As illustrated in Fig. 4c, in an exemplary embodiment, the external seal 140e includes an elastomeric seal 140ea that is retained within an external groove 140eb by a retaining element 140ec. In an exemplary embodiment, the external seals 140e fluidically seal the interface between the tubular seal assembly 140 and the wellbore casing 110.

[0026] During operation, in an exemplary embodiment, after the liner 120 has been radially expanded and plastically deformed into engagement with the casing 110, the upper end 120a of the liner 120 is then machined to provide the first beveled portion 120aa and the second beveled portion 120ab. The tubular locator 135 and tubular seal assembly 140 are then inserted into the interior of the casing 110, and the end 135a of the tubular locator is inserted into the upper end 120a of the tubular liner 120. The external seals 140c, 140d, and 140e of the tubular seal assembly then fluidically seal the interface between the tubular seal assembly and the casing. In this manner, the tubular locator 135 and the tubular seal assembly 140 provide a pressure sealed tubular liner for conveying fluidic materials to and from the tubular liner 120. In this manner, the need for a tie-back liner may be eliminated thereby providing a cost effective alternative to conventional methods and apparatus for providing a pressure sealed tubular liner.

[0027] An apparatus has been described that includes a subterranean formation defining a wellbore, a tubular wellbore casing positioned within and coupled to the wellbore, a first tubular liner positioned within the wellbore overlapping with and coupled to the wellbore casing, and a second tubular liner positioned within the wellbore and overlapping with and coupled to the first tubular liner. The second tubular liner is coupled to the first tubular liner by machining an end of the first tubular liner, and

inserting an end of the second tubular liner into the machined end of the first tubular liner. In an exemplary embodiment, the first tubular liner is coupled to the wellbore casing by radially expanding and plastically deforming the first tubular liner into engagement with the wellbore casing.

[0028] A method for extracting fluidic materials from a subterranean formation including a wellbore that traverses the formation and a wellbore casing positioned within and coupled to the wellbore has also been described that includes coupling an end of a tubular liner to an end of the wellbore casing, machining an end of the tubular liner, inserting an end of another tubular liner into the machined end of the tubular liner, and sealing the interface between the other tubular liner and the wellbore casing. In an exemplary embodiment, the method further includes radially expanding and plastically deforming the tubular liner into engagement with the wellbore casing.

[0029] A system for extracting fluidic materials from a subterranean formation including a wellbore that traverses the formation and a wellbore casing positioned within and coupled to the wellbore has also been described that includes means for coupling an end of a tubular liner to an end of the wellbore casing, means for machining an end of the tubular liner, means for inserting an end of another tubular liner into the machined end of the tubular liner, and means for sealing the interface between the other tubular liner and the wellbore casing. In an exemplary embodiment, the system further includes means for radially expanding and plastically deforming the tubular liner into engagement with the wellbore casing.

[0030] In an apparatus comprising a subterranean formation defining a wellbore that includes a wellbore casing positioned within and coupled to the wellbore and a tubular liner coupled to an end of the wellbore casing, a method of conveying fluidic materials to and from the tubular liner has also been described that includes machining the end of the tubular liner, inserting and supporting an end of another tubular liner in the machined end of the tubular liner, and conveying fluidic materials to and from the tubular liner using the other tubular liner. In an exemplary embodiment, the other end of the tubular liner extends through the wellbore casing. In an exemplary embodiment, the method further includes fluidically sealing the interface between the other end of the tubular liner and the wellbore casing.

[0031] The present illustrative embodiments of the invention provide a number of advantages. For example, using the machined upper end 120a of the liner 120 as a seal receptacle eliminates more costly and complicated conventional systems for providing a seal receptacle. Furthermore, the use of the tubular locator 135 and the tubular seal assembly 140 eliminates the more costly and complicated tie-back liner. As a result, the present illustrative embodiments provide a sophisticated yet less complex system for providing a pressure sealed tubular liner for conveying fluidic materials to and from the tubular liner 120.

[0032] It is understood that variations may be made in the foregoing without departing from the scope of the invention. For example, while the present system has been described in for use with a tubular liner 120 that has been radially expanded and plastically deformed into engagement with the casing 110, the teachings of the present embodiments may also be applied to tubular liners that are coupled to a

preexisting casing without radial expansion and plastic deformation. Furthermore, while illustrative embodiments of the present system have been presented for extracting oil and gas from a subterranean formation, the teachings of the present embodiments may also be applied to the extraction of geothermal energy from subterranean formations. In addition, in several exemplary embodiments, the seals 140c, 140d, and/or 140e, seal the interface between the tubular seal assembly 140 and the wellbore casing 110.

[0033] Although illustrative embodiments of the invention have been shown and described, a wide range of modification, changes and substitution is contemplated in the foregoing disclosure. In some instances, some features of the present invention may be employed without a corresponding use of the other features. Accordingly, it is appropriate that the appended claims be construed broadly and in a manner consistent with the scope of the invention.

What is claimed is:

1. An apparatus, comprising:
 - a subterranean formation defining a wellbore;
 - a tubular wellbore casing positioned within and coupled to the wellbore;
 - a first tubular liner positioned within the wellbore overlapping with and coupled to the wellbore casing;
 - a second tubular liner positioned within the wellbore and overlapping with and coupled to the first tubular liner;wherein the second tubular liner is coupled to the first tubular liner by:
 - machining an end of the first tubular liner; and
 - inserting an end of the second tubular liner into the machined end of the first tubular liner.
2. The apparatus of claim 1, wherein the first tubular liner is coupled to the wellbore casing by radially expanding and plastically deforming the first tubular liner into engagement with the wellbore casing.
3. A method for extracting fluidic materials from a subterranean formation including a wellbore that traverses the formation and a wellbore casing positioned within and coupled to the wellbore, comprising:
 - coupling an end of a tubular liner to an end of the wellbore casing;
 - machining an end of the tubular liner;
 - inserting an end of another tubular liner into the machined end of the tubular liner; and
 - sealing the interface between the other tubular liner and the wellbore casing.
4. The method of claim 3, further comprising:
 - radially expanding and plastically deforming the tubular liner into engagement with the wellbore casing.
5. A system for extracting fluidic materials from a subterranean formation including a wellbore that traverses the formation and a wellbore casing positioned within and coupled to the wellbore, comprising:
 - means for coupling an end of a tubular liner to an end of the wellbore casing;
 - means for machining an end of the tubular liner;
 - means for inserting an end of another tubular liner into the machined end of the tubular liner;
 - and
 - means for sealing the interface between the other tubular liner and the wellbore casing.

6. The system of claim 5, further comprising:
means for radially expanding and plastically deforming the tubular liner into engagement with
the wellbore casing.

7. In an apparatus comprising a subterranean formation defining a wellbore that includes a wellbore casing positioned within and coupled to the wellbore and a tubular liner coupled to an end of the wellbore casing, a method of conveying fluidic materials to and from the tubular liner, comprising:
machining the end of the tubular liner;
inserting and supporting an end of another tubular liner in the machined end of the tubular liner,
and
conveying fluidic materials to and from the tubular liner using the other tubular liner.

8. The method of claim 7, wherein the other end of the tubular liner extends through the wellbore casing.

9. The method of claim 8, further comprising:
fluidically sealing the interface between the other end of the tubular liner and the wellbore casing.

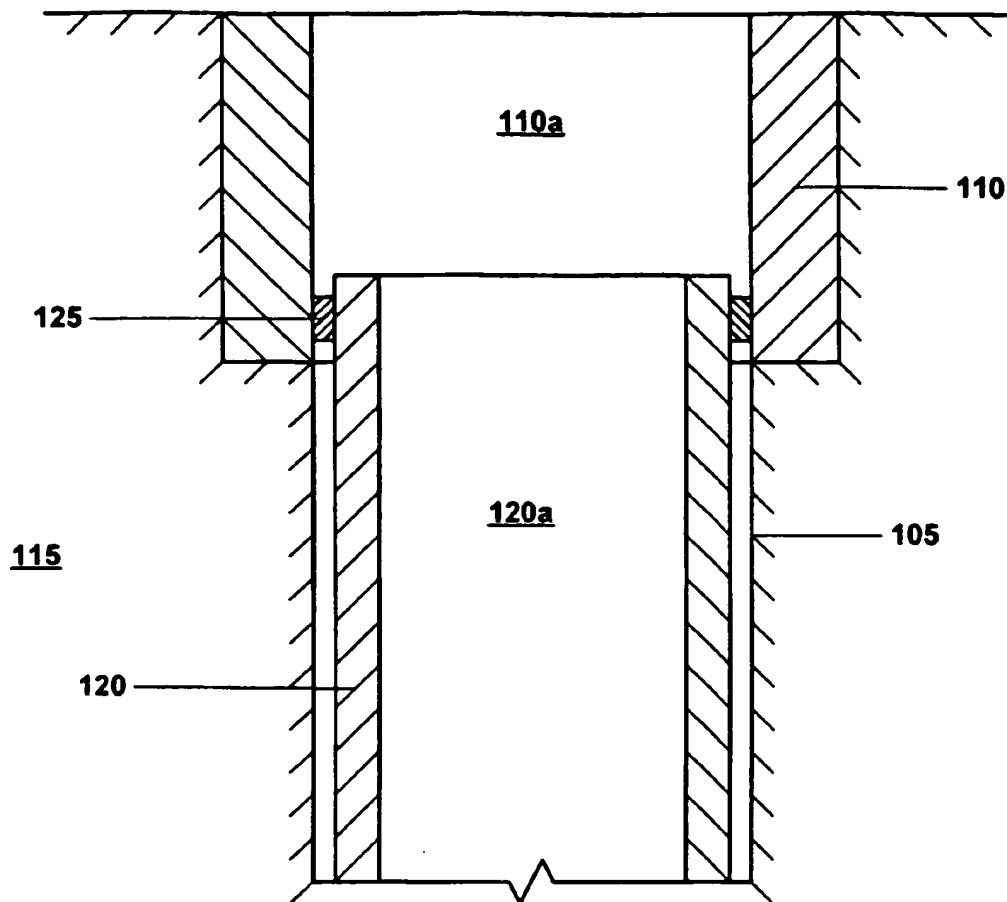

Fig. 1

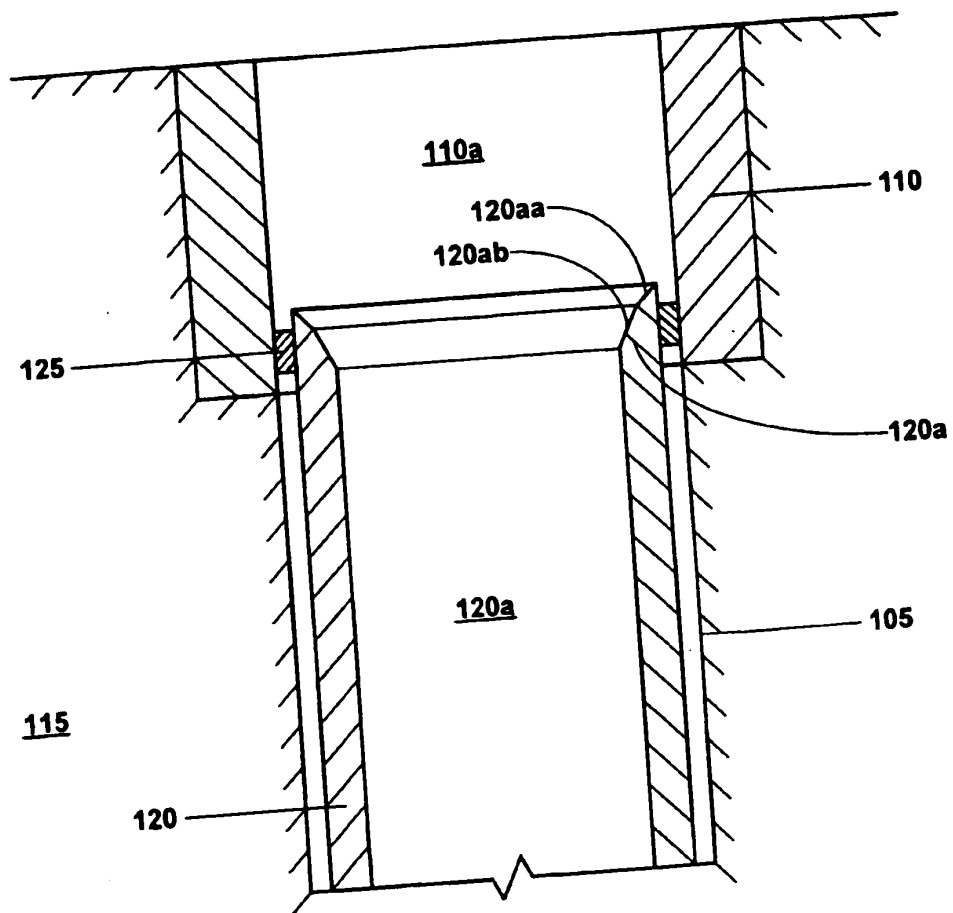

Fig. 2

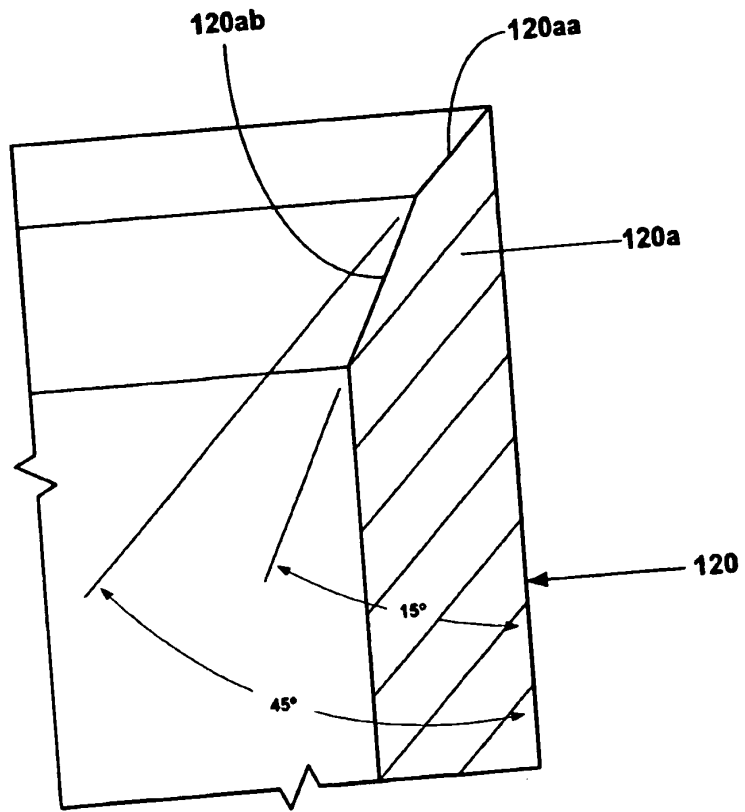

Fig. 2a

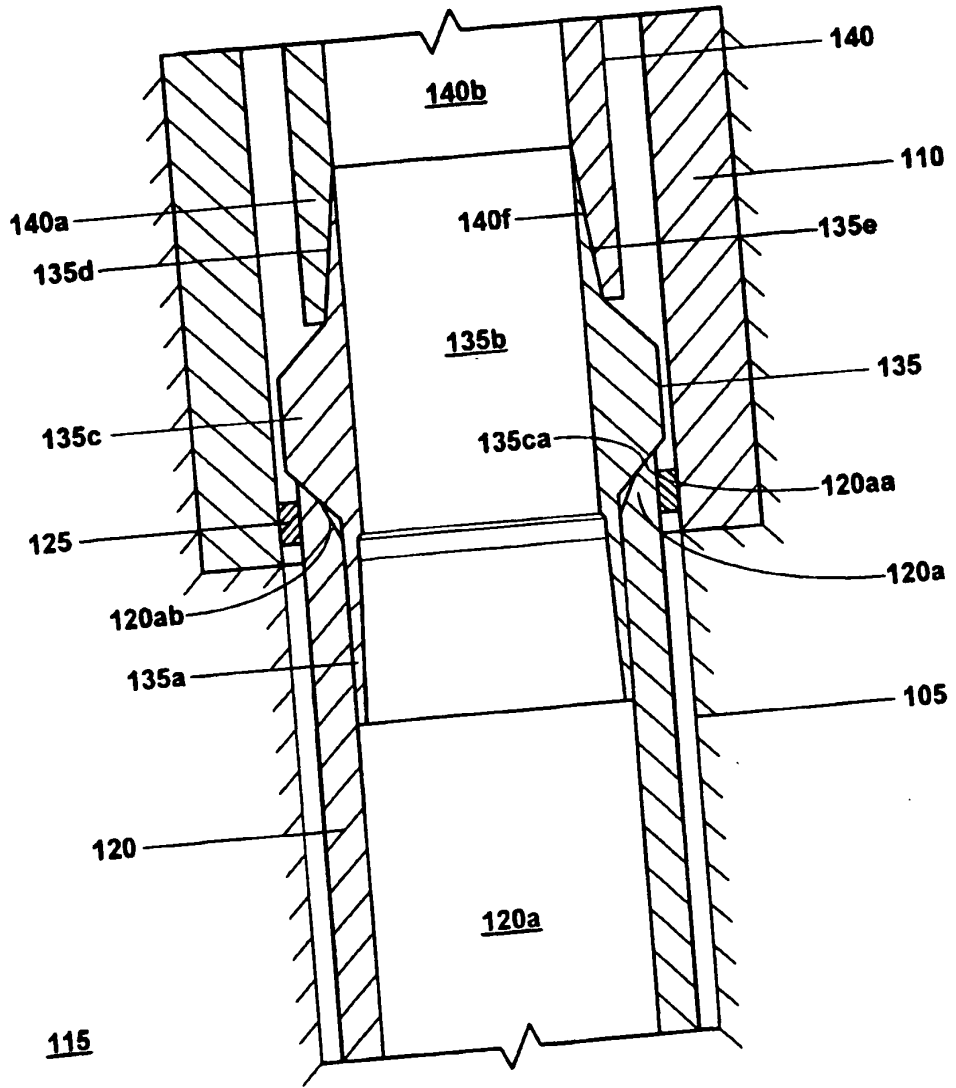

Fig. 3

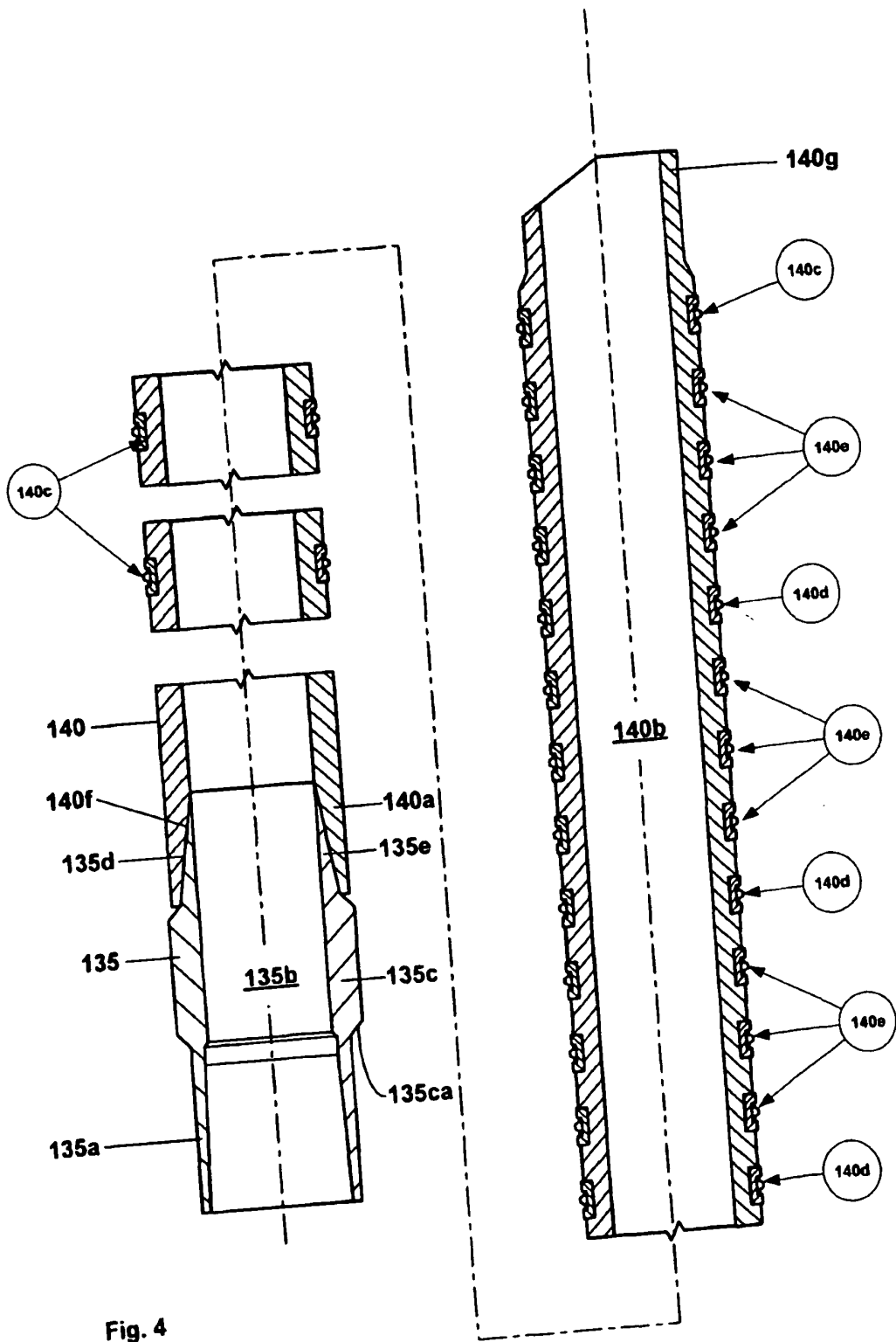

Fig. 4

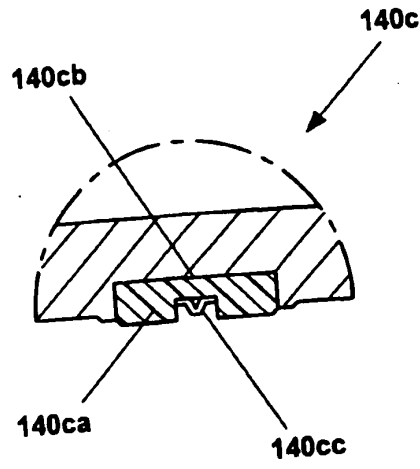

Fig. 4a

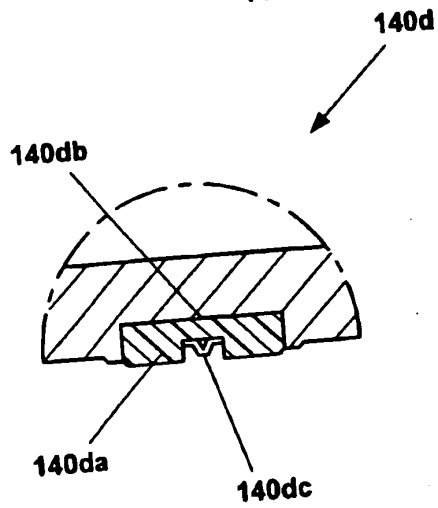

Fig. 4b

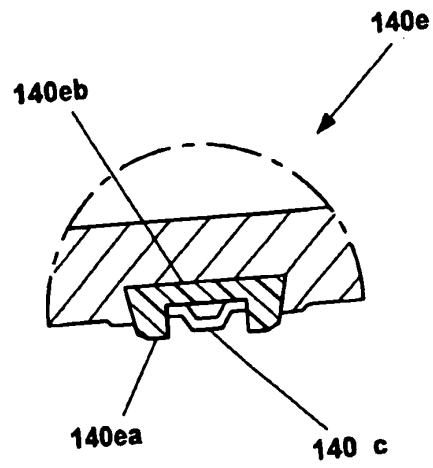

Fig. 4c